

## A SMORGASBORD OF PACKAGES - PETITE & LIGHT

Dr. Ken Gilleo  
ET-Trends; Ken@ET-Trends.com  
Rhode Island

### ABSTRACT

*We are already into the second decade of the Packaging Revolution that has made strides in conquering Space & Time by transitioning to efficient area array and minimal, often chip-size packaging. While some CSPs and all Flip Chips have achieved the smallest device-dimensioned foot print possible, some ask for more in their quest to compress the world into a microcosm. Other packaging innovators have invoked the 3<sup>rd</sup> dimension to stack chips in high-rise fashion. Some may even contemplate a 4<sup>th</sup> dimension. While this may seem amazing, keep in mind that submicroscopic DNA contains one million pages of code.*

*The flex-based packaging arena has also gained stature by losing height and shedding weight with 25-micron materials that produce lines and spaces approaching but a few microns with vacuum-deposited metal. Flex-BGAs are gaining share as they reach for the high-density and lightweight titles.*

*And just when the industry could almost take a rest, there came a new assault from an unexpected camp. MEMS (micro-electro-mechanical systems) was thrust onto center stage as Internet giants embraced lightwaves and sought photonic switching solutions. The MEMS devices that “move, breathe, see, hear and think”, require totally new packaging. Then came the second volley from the same camp when optics was added to bring MOEMS (micro-opto-electro-mechanical systems) into focus. The Internet seeks to catch the wave with magical micro mirrors that would snatch a light beam and route it into cyberspace. The opto devices now demand windows in their package along with other new and challenging amenities.*

*This paper will review and update the exciting Package Revolution describing packages that were, those that are and some that are only dreams. So come to the island to catch the wave and find out if the big one is sound, solder, ocean or light!*

**Key Words:** Bluetooth, MEMS, MOEMS, photonics, wireless.

### INTRODUCTION

Where are we heading in the new millenium? We must answer this broad question before discovering the paths that technology will take. This is certainly a time of unusual prosperity, business success, unprecedented change and technical breakthroughs. We are on the verge of unraveling human DNA coding that promises new,

molecular-programmed medical solutions. But more immediate, we are surrounded by the all-pervasive Telecom Revolution that will ultimately link any two people in the world together. The telecom area presently has the greatest influence on our industry and our lives although biotechnology will surge later with even more impact.

The convergence of many technologies to enhance and enable new and old industries is providing the greatest change agent for devices, packages and assembly. MEMS and photonics has moved from niche markets to mainstream. Lab curiosities from the nano-world have penetrated the commercial world and this is just the beginning. Government agencies sponsored information-gathering workshops in year 2000 and new and significant funding is now promised to accelerate these emerging technologies. Since the device is changing, so must the package. Let's now look at what has happened and try to anticipate the most likely events that will unfold.

### TELECOM

The Internet can be viewed as the center of telecom – the hub of world communications. The worldwide system can be divided neatly into segments that are defined by signal run length. The main line, or trunk network, is called the long haul or core. The long haul networks span countries and continents with run lengths that can be over 1000 km (621 miles). This segment carries the highest volume of traffic. The long-haul links may run from Boston to Chicago to Los Angeles, for example, but there is a fairly extensive network with nodes in major cities. The long haul pipes then continue to coasts and then into the sea using submarine optical cable. This global network will soon connect all large and moderate landmasses together and the world will be “wired” with glass. Many new submarine cables were deployed in Asia and Europe just during 2000. Figure 1 shows the network map. Let's look at long haul technology.

### Long Haul Terrestrial and Submarine Communications

Photonics is the dominant medium for terrestrial and intercontinental submarine links and is used in all new lines. Photons are massless, chargeless quanta of “light” energy that travel unimpeded at 186,000 miles per second (300,000,000 meters/sec.). Photonics provides the fastest and most cost-effective media. A photonic signal could circumnavigate the globe seven times just during a single beat of your heart. Photonics also has the greatest bandwidth (bits/second), a metric that includes much more than signal velocity. Bandwidth is a composite of data rate per second per line multiplied by the number of individual signals. Light unequivocally wins over electronics as the preferred data messenger for many reasons. First, light is at a much higher frequency than is possible with electronics, even radio

frequency (RF) in gigahertz bands. Higher frequency directly correlates to higher data rate. Light is readily split into a rainbow of individual colors using prism-like passive components and each one can serve as a separate data carrier. The technology is called WDM for Wave Division Multiplexing and it effectively boosts the bandwidth by several hundred times although the physical limit is many thousands. All of the split wavelengths, or lambdas, can travel through a single extremely thin fiber. Now add more fibers to the terrestrial or submarine cable and bandwidth is essentially unlimited. The newest DWDM (Dense Wave Division Multiplexing) systems, using a single hair-thin glass fiber, can carry the equivalent of 12,000 encyclopedias per second or 5-million simultaneous phone calls making electronics all but obsolete in this arena.

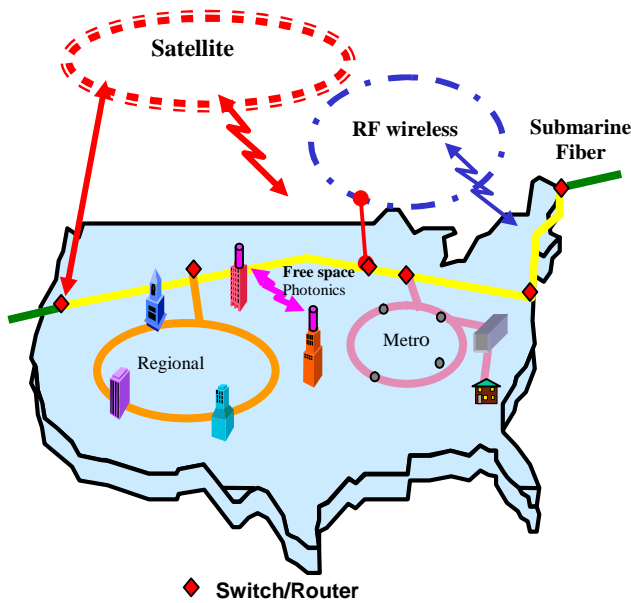

Figure 1 – Internet & Links

**Hardware**

A photonics communication system is made up of light transmitters (modulated lasers), demultiplexers (color splitters), conductors (optical fibers), switches/routers multiplexers (color combiners), and receivers (detectors). The system also contains amplifiers (erbium-doped fiber amplifiers) and an assortment of analyzers, signal conditions and the like. New developments are occurring in all areas but the most exciting is in optical switching. Right now, the optical signal is converted to electrical so it can be switched with well-understood solid state electronics. Once routed, the electronic signal is converted back to light. The industry is working very hard to move to all-optical switches where light will be routed directly using micro-photonic devices. They are called optical MEMS (Micro-electro-mechanical Systems) and also MOEMS (Micro-Opto-Electro-Mechanical Systems). Figure 2 shows the electro-optical conversion issue while Table 1 compares electronics to photonics switching. The double conversion becomes increasingly problematic as more and more wavelengths are added to the data stream.

This fast-emerging area is a major new opportunity for the semiconductor, packaging and assembly industries, but more later.

**Interconversion**

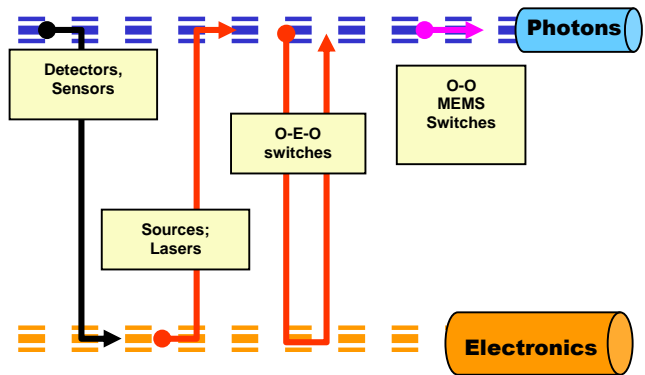

Figure 2

Characteristic	Electronics	Photonics
Bandwidth	Low	Very high
Cost/bit	Medium	Very low
Noise, interference	High	Very low
Infrastructure	Established	Emerging
Reliability	High	High
System lifetime	Proven	Unknown
Scalability	Poor	Good
Router size	Large	Potential small
Status	Deployed	Emerging

Table 1 – Switch Characteristics

**Metro Rings**

The long haul segment feeds data to the next level down, the metros that are also shown in Figure 1. While there is less data than the long haul, the amount of information can still be considerable. Metros are typically laid out as a fiberoptic ring that encircles the city or other populated region. One valuable feature of photonics is that signals can be sent in both directions without interference. The ability to reroute data in the opposite direction provides a pseudo redundancy. While metros use fiber, they switch electronically although a few are testing all-optical switching. Some metros have already upgraded to WDM but not to the extent of the higher traffic long haul. The metros require more switches per run length than long haul and are thus more cost sensitive to hardware. At this stage, the limited number of lambdas used by a typical metro can be handled using Optical Add-Drop Multiplexers (OADM). These are hybrid electronic photonic systems that either allow (add) a given wavelength to pass into a fiber or block (drop) it. Using cross switch architecture, an incoming signal can be routed to the desired fiber. OADMs are now built using conventional SMT solder assembly but with manual assembly of optical components. Large OEMs, like Lucent, assemble these massive OADMs, but Celestica and other contract manufacturers also do such work. This area represents immediate opportunities for SMT assemblers.

Figure 3 shows the add-drop switch design. A typical unit weighs several pounds, occupies many square feet and sells for over \$30,000 each.

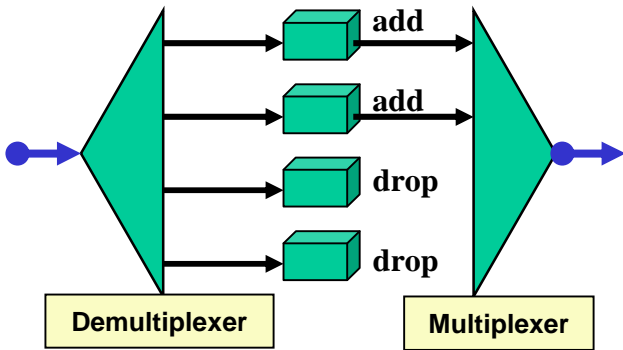

Figure 3 – Add-Drop Concept

#### Down Stream Links

The metro rings supply enterprise networks and individual users. Most enterprise networks are built on copper wire electronics. However, some cable systems run fiber to the pole but convert to electronic signals to run copper coaxial cable to the home. Many predict that photonics will run directly to the home in the future as more services are added. Future systems may transmit digital TV, Internet, music, movies, phone and new services through fiber that is distributed within the house or building. This area is one that will ultimately bring very high volume packaging and assembly to the industry, but timeline estimates vary from 5 to 15 years.

#### Wireless Communications

High-speed fiber and coax may be fine for those who don't mind tethers but wireless is here today and expanding rapidly. A modern cell phone will link you to the Internet. You can receive e-mail, check stocks, news, weather and more. Alerts can be set for stocks, the weather and news. E-mail sent from any Internet system anywhere in the world will appear on your cellular phone as text that can be scrolled. The phone alerts you when the message is received so you can quietly read during one of those boring meetings that still exist. And if you need to see graphics or surf the web, just plug in your laptop to reach the Internet at modest speeds. Or maybe you already have a Bluetooth enabled phone that connects to the laptop by short-range wireless. The theme song of telecom is, "Send data not DNA (people)".

#### Free-Space Photonics Wireless

Wireless is typically associated with radio waves but the first wireless actually used photonics. Around 1880, Alexander Graham Bell sent voice to ships using a modulated light beam and a selenium photocell receiver. He considered his Photophone to be much more significant than the telephone that made him rich and famous. Bell was correct, but it took over 100 years for all the breakthroughs needed to make the idea more practical.

Figure 4 shows the Bell Photophone. Today, high-speed infrared beams link buildings together to provide Internet and other modes. While the *fiberless* optics systems are used for business communications, the time may come when your computer, PDA and cell phone link to the Internet using free space photonics.

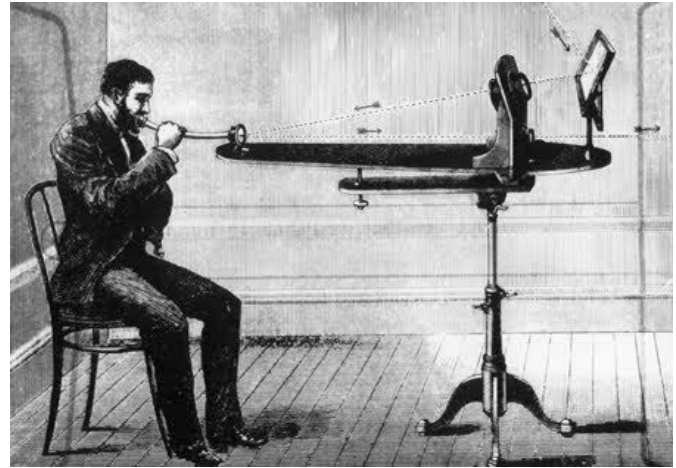

Figure 4 – Bell and his Photophone (Lucent)

#### Radio Frequency RF Wireless

Bluetooth wireless technology (radio frequency at 2.45-2.5GHz) is a de facto standard, as well as a specification for small-form factor, low-cost, short-range radio links between mobile PCs, mobile phones and other portable devices. Bluetooth enables users to connect a wide range of computing and telecommunications devices easily and simply without connection cables. It enables invisible "connections", and the automatic, transparent, linking between devices. Because Bluetooth wireless technology can be used for a variety of purposes, it will also eventually replace multiple cable connections via a single radio link. This is an immediate opportunity for our industry with a total market in the billions of dollars. The high frequencies require special devices, packages and perhaps changes in substrate. Bluetooth is a very high volume technology and is expected to find its way into computers, printers, cameras and cell phones. Motorola is already shipping StarTac™ phones with Bluetooth modules. Contract assemblers are already involved in Bluetooth programs. See reference web [6] for more.

#### THE PHOTONICS PACKAGE?

The package must house and protect the device while performing a geometric and materials translation so that silicon and circuitry become compatible. Nearly all of the packages that we have dealt with were connected to the outside world through metal leads using electrons. MOEMS require a second interface so that light may enter and exit. This means that the package must have transparency or use some form of light piping. What's more, the moving parts typically found in MEMS, must be free to move [1]. Also add the requirement that moisture must be kept extremely low so that optics won't fog or degrade. MOEMS introduces a major packaging challenge, especially if the package is to be

economical. Let's examine the status of MOEMS packaging and some of the new ideas being proposed [2].

**Hermetic Packaging**

Metal and ceramic hermetic sealed packages have been the ultimate solution for maintaining a precise environment around devices ever since the vacuum tube – the first hermetic enclosure. Most of the optical MOEMS are hermetically packaged but with a transparent lid so that light may pass. Texas Instruments, perhaps the company with the most MOEMS experience, has used hermetic packaging for their DMD™ (Digital Micromirror Device) for many years. The package uses special molecular scavengers, called getters, to extract and trap optics-damaging moisture and micro-particles that could prevent movement of the 10's of thousands of micro-mirrors [3]. Figure 5 shows the package design while Figure 6 shows a close-up of the MEMS mirrors. There are two problems with most hermetic enclosures, however. Most cannot be assembled with automatic SMT

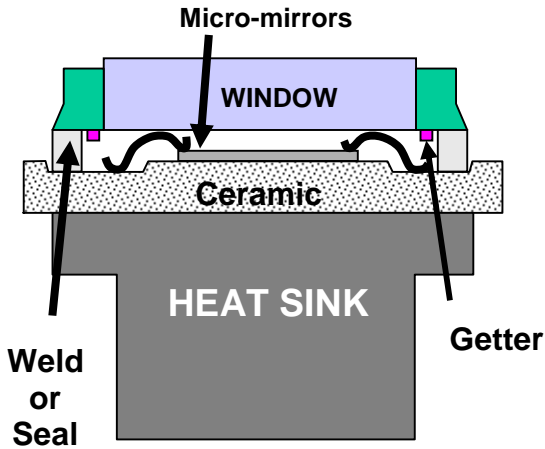

equipment and these packages can be very expensive.

Figure 5 – MOEMS Package Design

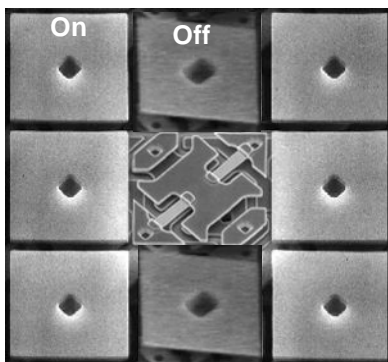

Figure 6 - DMD™ Structure [3]

**Quasi-hermetic**

One way to reduce cost is to move to a quasi- or near-hermetic packaging design. Soldering, welding or some other high temperature process commonly bonds a

package lid. This adds cost and stress and is more difficult if the lid is made of a transparent material. A lid sealed with polymer adhesive could save money and reduce thermal stress. Many adhesives systems, both thermoplastic and thermoset, have been designed for such applications and products are in commercial use. Unfortunately, polymers are not a perfect barrier to gases. The adhesive seal therefore results in a slow leak that is determined by composition and the dimensions of the seal. Texas Instruments has investigated quasi-hermetic packaging for the DMD with encouraging results [4]. Getters were used and appear to be an essential ingredient although no through study has been reported. However, a study of quasi-hermetic packaging and the affects of getters will hopefully occur in the future [5].

**Packaging Ideas**

Let's now look at some of the new SMT packaging concepts for MOEMS. The idea here is to keep size and cost low while enabling light transmission, hence "packages petite and light". There are at least three approaches: (1) transparent lids, (2) transparent substrate (chip carrier), (3) optical encapsulants and (4) light pipes. Concept (1) has already been designed and prototyped by Chip Scale Package (CSP) manufacturer ShellCase. Their ShellOp™ package uses a glass cover to enable light transmission. The product is in testing but reliability data has not yet been reported. This MOEMS-capable package could be assembled using SMT methods and does not require underfill. The ShellOP package appears to be the only wafer level chip size package solution available today for image sensors. Its total package thickness is 0.6 mm. Figure 7 shows the package concept.

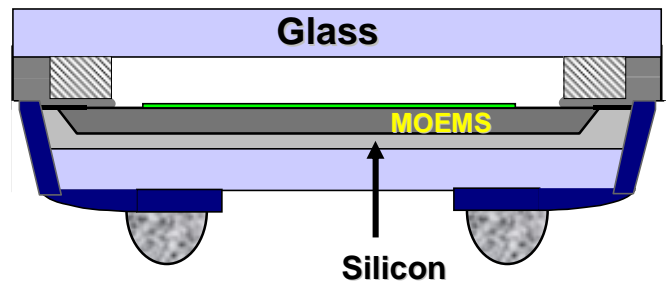
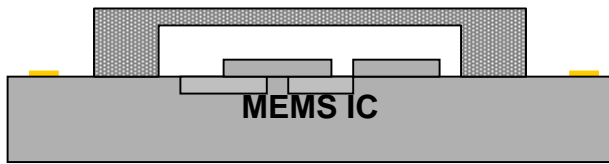

Figure 7 - ShellOp

Wafer-level packages have been proposed and may have already been implemented. One concept has been called "Cap-on-Chip" and also "Zero Level". A protective silicon cap is placed over the sensitive MEMS area and sealed to create a micro-hermetic package even before the chip is actually packaged. There are a number of researchers working in this area and there are many different designs. Some accelerometer packages may even be commercial at this time. Accelerometers, long used as air bag sensors, are now found in electronic games and toys where motion is translated into action. Once the cap is placed, the package can now be handled more conventionally and even encapsulated by liquid dispensing or transfer overmolding. Figure 8 shows the Cap-on-Chip principle.



**Figure 8 – Cap-on-Chip**

The same design concept could be used for MOEMS devices but with transparent materials. Quartz or glass could be used for the cap and optically clear encapsulants would be applied in the final step. Figure 9 shows this concept using encapsulation with optical polymers.

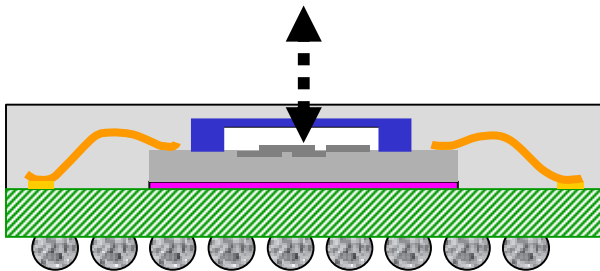

**Figure 9 – Optical MEMS package**

A sealed opaque package can still be used for MOEMS provided that there is a light path formed with a transparent porthole or an optical fiber. A simple concept may be to build a flip chip in package (FCIP) so that the resulting gap will provide built-in clearance for the mechanical motion. The gap height needed for the clearance can be controlled by several methods including the use of partially collapsible bumps or even non-fusible bumps. Gold stud bumps could be bonded with conductive adhesives using an assembly method already used for memory modules. Once the FC is assembled, underfill is probably required. However, the package could be designed to restrict flow around the optical port or by using a perimeter underfill. Optical fiber or a light port could interface with the chip. A polymer fiber could be used since the modestly greater attenuation compared to glass would be insignificant because of the short path. Possibly a quartz insert could also be used. Figure 10 shows one of these MOEMS FCIP concepts.

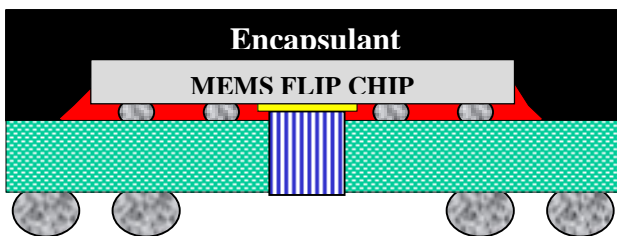

**Figure 10 – FCIP for MOEMS**

Finally, the chip carrier could be made of glass or some other optically clear material. HyComp has studied flip chip assemblies using glass circuits made by vacuum

deposition thin film methods and such a process could be used to build carriers. However, Intarsia already builds CSP and hybrid circuits on glass using a BGA interface. The FC could be added that would communicate with the main board through the glass platform. Figure 11 shows a standard Intarsia circuit/package using this film on glass technology.

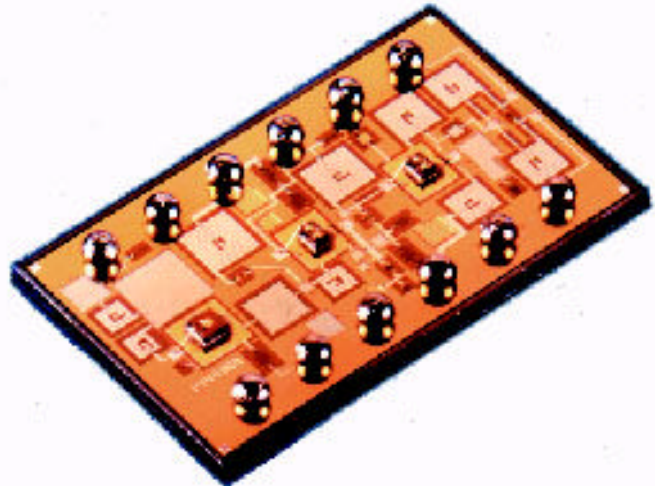

**Figure 11 – Intarsia**

### BLUETOOTH PACKAGES

For those who feel more comfortable with pure electronics but want to be on the leading edge, Bluetooth may be for you. The Bluetooth two-way radio system includes antenna, radio transmitter/receiver, flash memory and software. But it can all fit into a single package. This is really a system in package. The software and memory will be embedded in the device. The is a gigahertz frequency module but only within the package and the mother board will operate at lower frequencies. One likely package is an 81 ball rigid CSP probably made with ceramic. Bluetooth progress can be tracked on the consortium website [6].

### WHAT ABOUT ASSEMBLY?

#### MEMS and MOEMS devices

Let's begin with the accelerometer, one of the earliest and most important MEMS devices. The chip typically has a sensitive cantilevered silicon arm or a comb that bends slightly when there is a change in motion. Movement is detected and translated into an electrical response. The system must accurately sense deceleration and send the signal that fires your airbag. The deployment signal must only trigger under crash conditions. "Almost right" is not good enough in a life and death situation as has been shown in some unfortunate incidents. Anything that increases package stress will change sensitivity so assembly is under new rules and constraints [7].

The accelerometer (deccelerometer) must sense change in motion but not in all directions. The sensor must detect the rate of change primarily in the forward direction of the vehicle. We don't want the air bag activated if the vehicle is rear-ended or hit from the side or bounced by a pothole. While more cars are employing side air bags, their separate sensors detect side-ways motion. Anything that interferes with sensing

the direction or alters the ability to detect absolute deceleration will be a problem. Let's look at how circuit assembly can affect things.

Here are some assembly issues. Package orientation must be right. Skew reduces sensitivity since the MEMS device will not point true. Hypothetically, if the package were to be skewed by 45°, the forward direction sensing would be reduced by half. While it may not be possible to have that degree of skew, some is likely. Component tilt is not good since this will also change the effective direction of motion and reduce sensitivity. How much skew and tilt can be tolerated? Is it perhaps possible to even design a package that will always assemble close enough? These are some of the questions that may already have well-established answers but the information may not be readily available.

These are some of the more obvious assembly concerns, but there are many more that involve a change in sensing. We asked if the solder fillet was critical and the answer is "Yes", but for mechanical not electrical reasons. Even the lead compliancy plays a role in determining what the sensor "feels" in a high impact crash. Stiffer leads will

LED/photosensor "plugs" analogous to electrical edge-card connections found in PCs.

### CONCLUSIONS & PREDICTIONS

Telecommunications has finally replaced the computer as the most important market driver. The Internet is the worldwide hub for global communications and it has embraced photonics as the highly preferred mode for terrestrial and undersea links. The packaging and assembly industries are learning the new rules of light as we add a whole new technology to electronics. But we have become accustomed to the freedom of portable electronics and the trend is accelerating. Wireless is getting a big boost as cellular phones link up with the Internet and laptops talk to cell phones. Both radio frequency (RF) and photonic wireless devices and systems are being introduced at a hectic pace. The new wireless short-range cable-less interconnect, Bluetooth, is just taking hold. The combination of electrons, photons and wireless/fiberless waves will bring new joys and frustrations to packaging and assembly. So let's catch the waves, light, radio, solder...and the ocean!

### REFERENCES

- [1] Gilleo, K., "MEMS Packaging Solutions", pp. 49 - 50, 52 - 53, 55 - 56, EP & P, June 2000.
- [2] Gilleo, K., "MOEMS the Word", Circuits Assembly, pp. 28 - 31, 33, 34, Nov. 2000.
- [3] Mignardi, M., "From ICs to DMDs", TI Tech. Journal, pp. 56 - 63, July - Sept. 1998 (<http://www.TI.com>).

allow less deformation and this results in a stronger signal. The assembly challenge appears to be complex.

Even the PWB characteristics must not change, but because of yet another affect. We mentioned that stress on the device, while permitted within limits, must be predictable. While Cerdip packages are popular for MEMS, there is changeover to plastics that can increase stress and its sensitivity. The manufacturer may calibrate the device during packaging as part of test, but if the assembly processes later causes unexpected changes, there will be problems. For example, board warpage and twist could be devastating. Even a change in the CTE (Coefficient of Thermal Expansion) of the laminate would need to be taken into account. The more we delve into assembly, the more questions arise. We don't even know "what we don't know" at this point.

MOEMS packages will have some of the same sensitivities but adding a light path certainly requires new considerations. Critical alignment may be required in some cases. Photonic packages will need to communicate with other optical systems on the board. Optical fibers will be used for others and precise fiber alignment could be needed. On the other hand, plug-in optical connectors are available and this could simplify assembly. Some optical connections will simply be made with [4] Jacobs, J, & Malone, J., "Suitability of an Epoxy Seal for a MEMS Package", Proc. 33<sup>rd</sup> International Symposium on Microelectronics, pp. 586 - 591, Boston, MA, Sept. 20 - 22, 2000.

[5] NSF: Report title will be "Research Opportunities in MEMS Manufacturing: Report of the NSF 2000 Workshop on Manufacturing of Micro-electro-mechanical Systems" Published by Department of Mechanical and Aerospace Engineering, Arizona State University, Tempe, Arizona 85287-6106.

[6] <http://www.bluetooth.com>

[7] Gilleo, K., "MEMS PCB Assembly Challenge", pp. 62, 64, 66,68,70, Circuits Assembly, March 2000.